

OR系列減壓閥 / OR Series Regulator

外形尺寸圖 / Overall Dimension Drawing (mm)

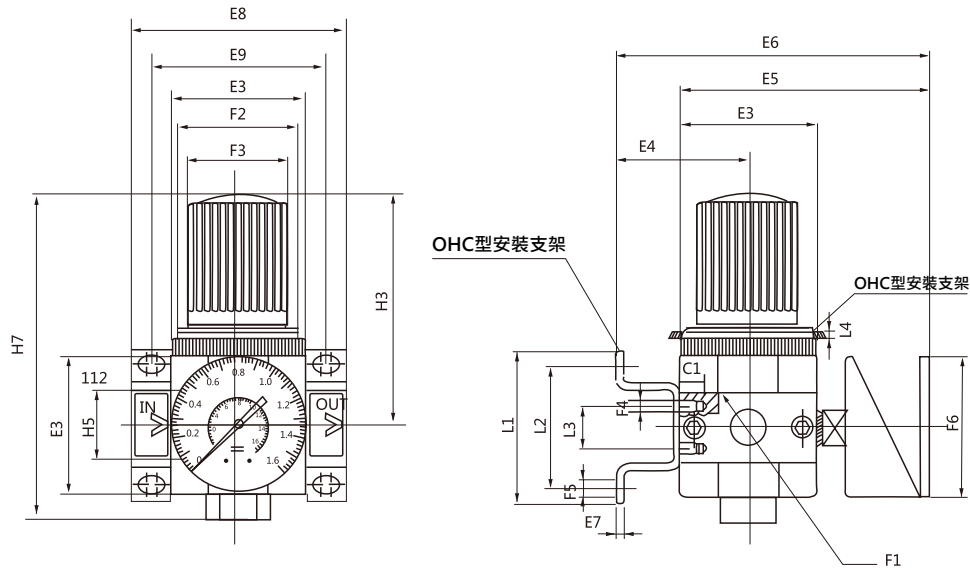

外形尺寸/Dimension

型號 / Model	E3	E4	E5	E6	E8	E9	F1
OR-...-MINI	40	39	76	95	64	52	G1/8 G1/4 G3/8
OR-...-MIDI	55	47	93	112	85	70	G1/8 G1/2 G3/4
OR-...-MAXI	66	53	104	124	96/116	80/91	G3/4 G1

外形尺寸/Dimension

型號 / Model	F2	F3Φ	F4	F5Φ	F6Φ	L1	L2	L3	H1
OR-...-MINI	M36×1.5	31	M4	4.5	40	44	35	11	194
OR-...-MIDI	M52×1.5	50	M5	5.5	52	71	60	22	250
OR-...-MAXI	M36×1.5	31	M5	5.5	63	71	60	22	252

外形尺寸/Dimension

型號 / Model	H3	H4	H5
OR-...-MINI	69	17.5	20
OR-...-MIDI	98	24.5	32
OR-...-MAXI	80	24.5	32/40

標準額定流量 q_n 和輸出壓力 p_2 的關係 / Standard Flow Rate q_n as Function of The Outpt Pressure p_2

OR-1/4-MINI

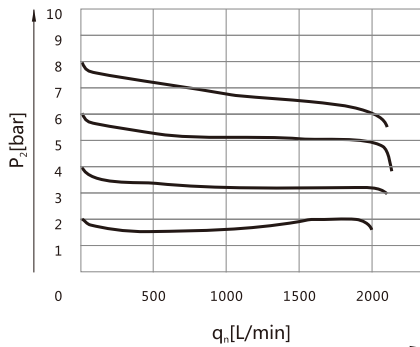

OR-1/2-MIDI

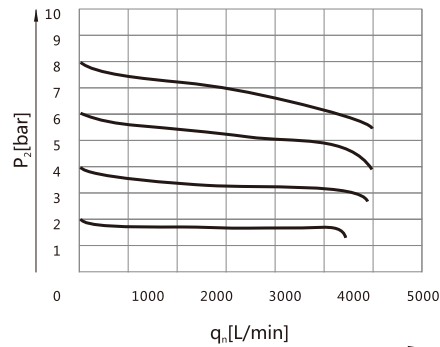

OR-1-MAXI

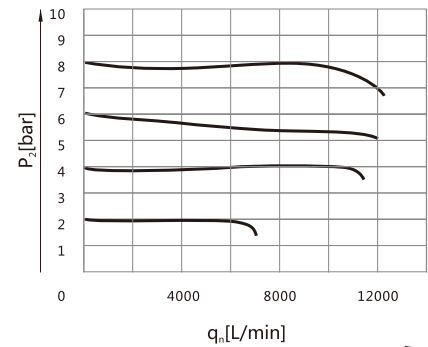

輸入壓力 $p_1 = 10$ bar